

**HADDON AVENUE PHASE 1 CORRIDOR**

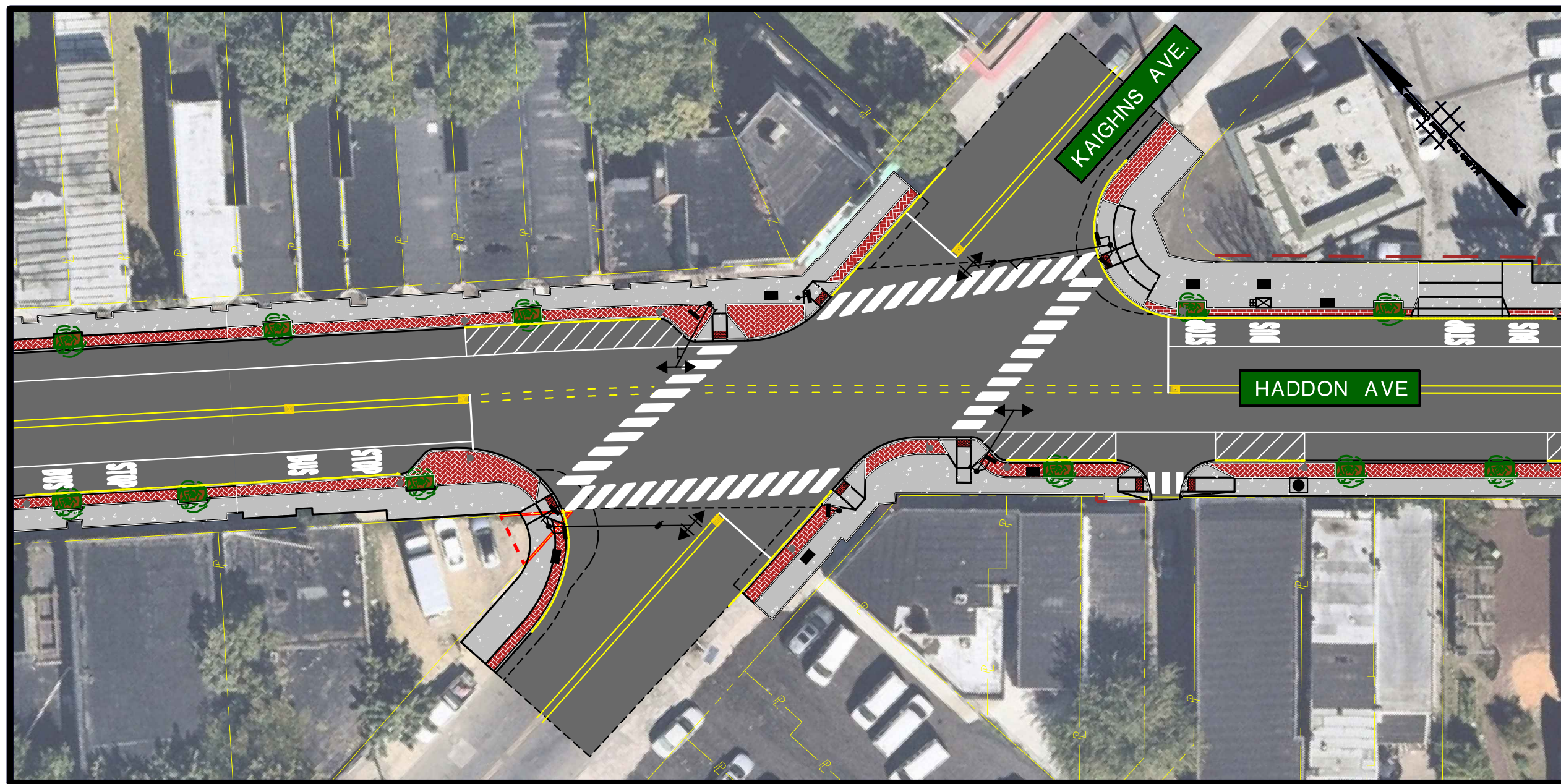

**HADDON AVE & KAIGHNS AVENUE INTERSECTION**

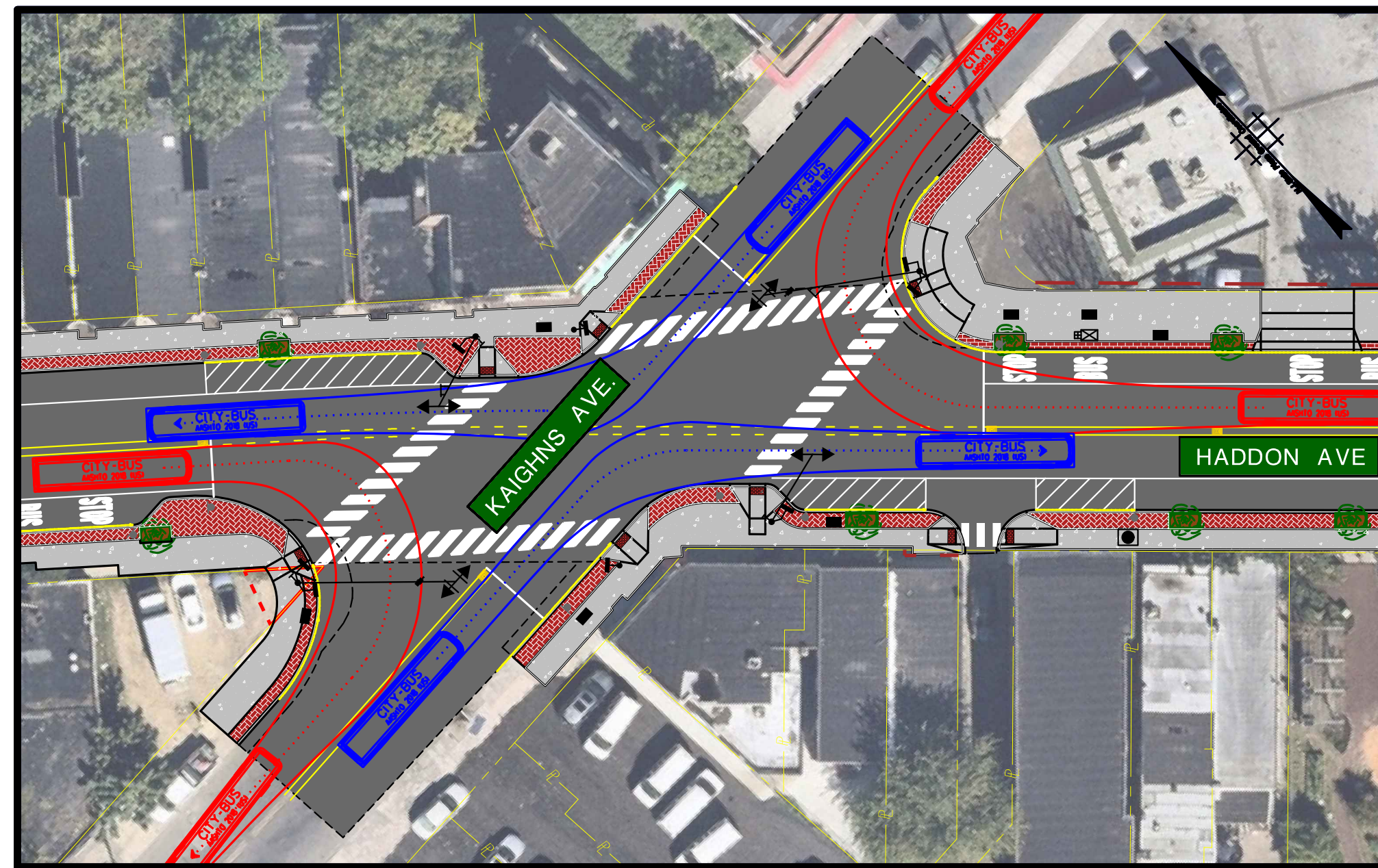

**BUS TURNS AT KAIGHNS AVENUE**

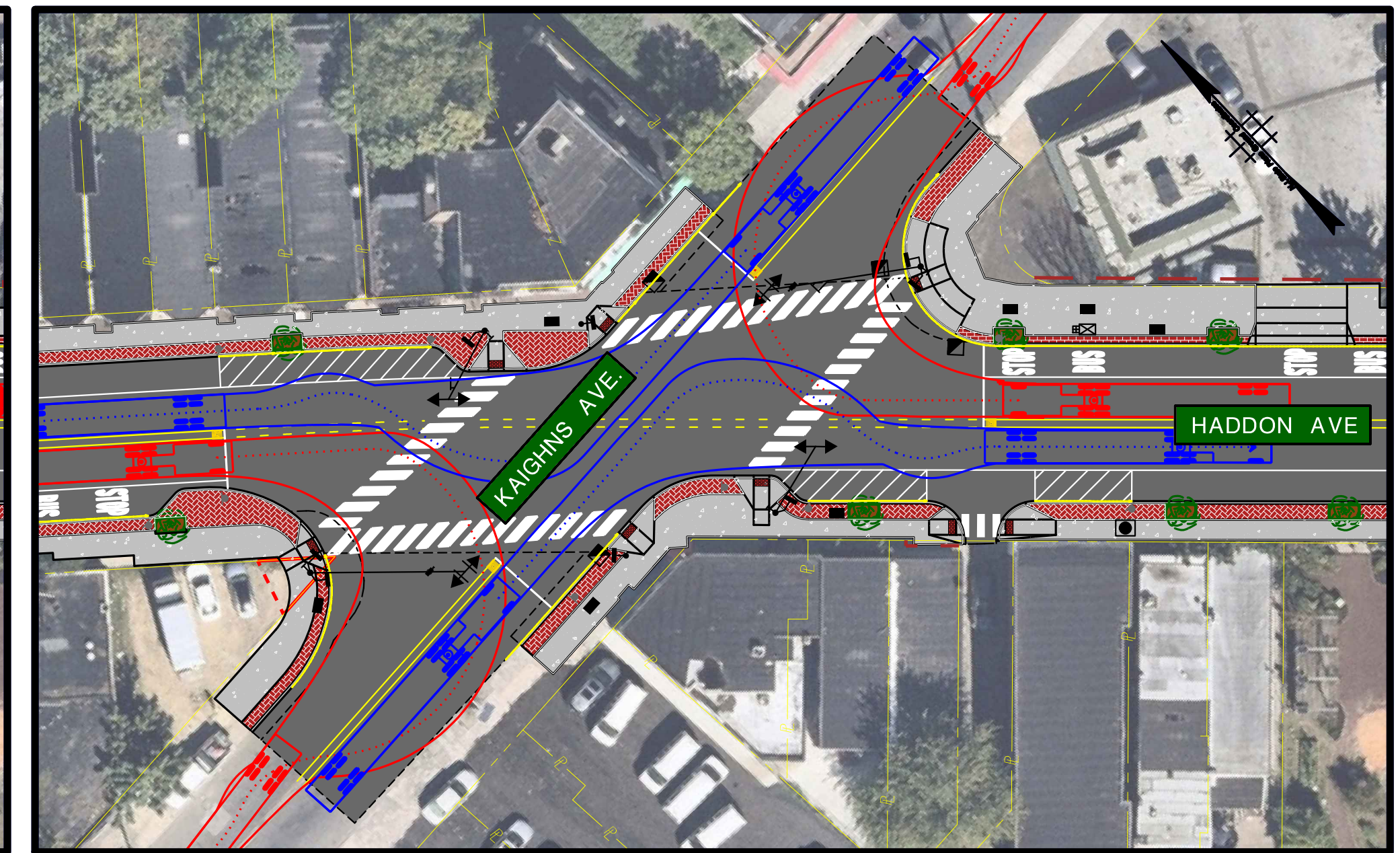

**WB-62 TURNS AT KAIGHNS AVENUE**

**GREEN INFRASTRUCTURE EXAMPLES**

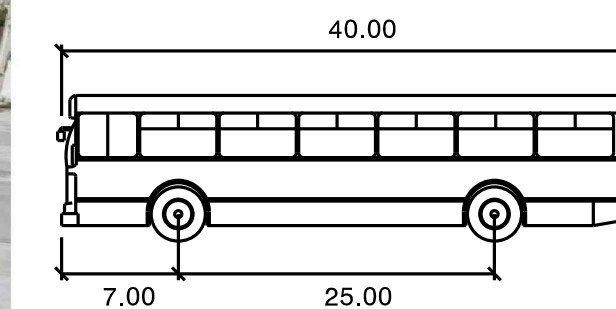
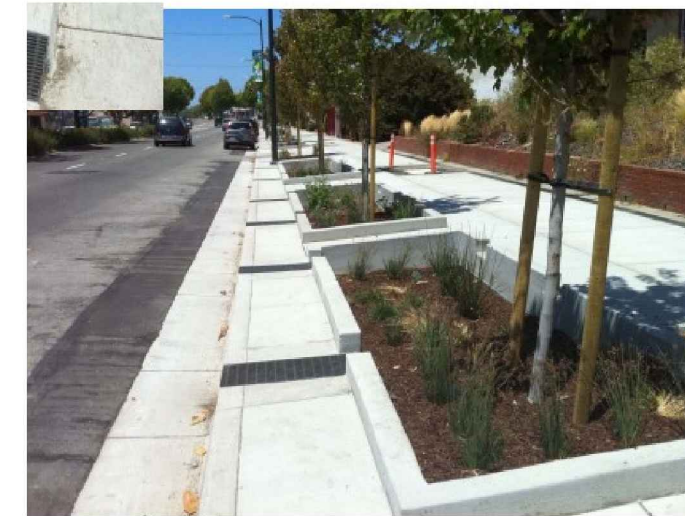
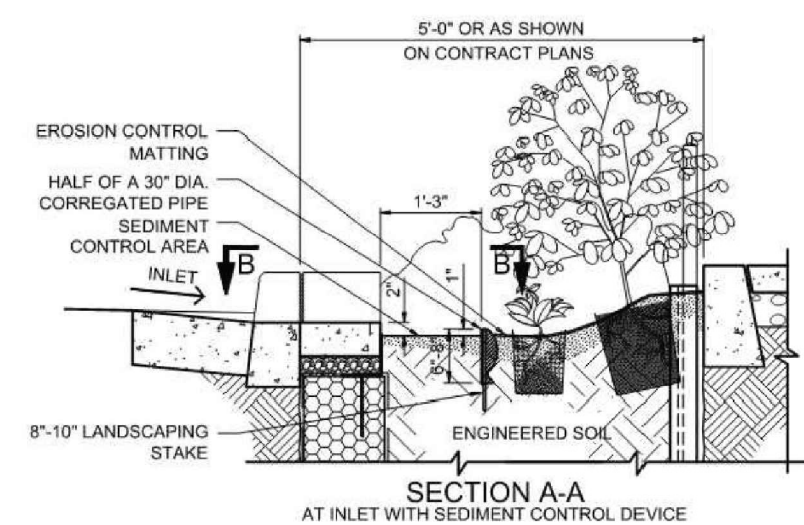

**CITY-BUS**  
Width : 8.50

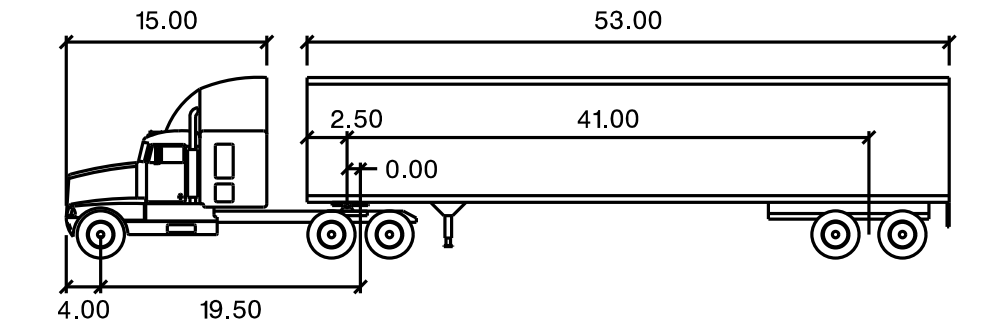

**WB-62 Modified (WB-67 Trailer with modification)**  
Tractor Width : 8.00  
Trailer Width : 8.50